

DC Jack Conn.

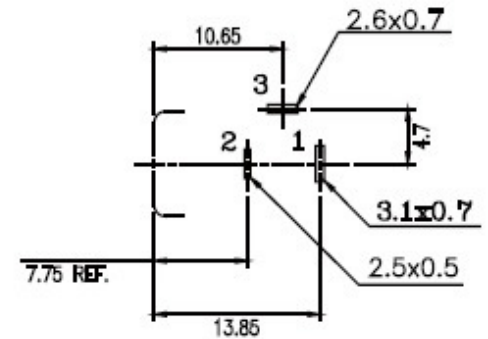

Part No.: DCJ  S-0014TB-L
 20: $\phi 2.0$
 25: $\phi 2.5$

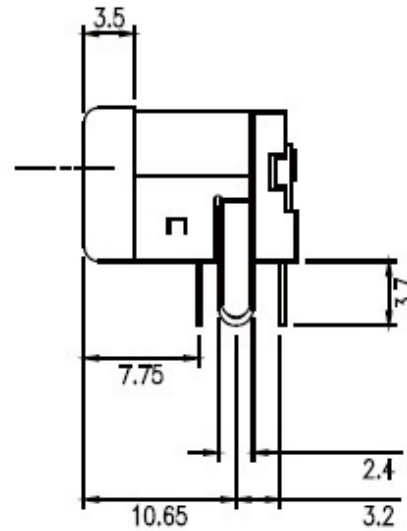
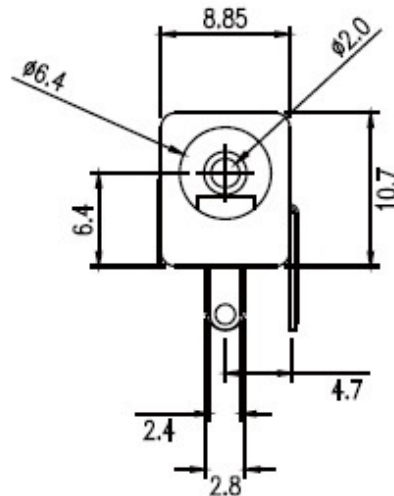

Recommended PCB Layout
(PCB TOLERANCE ± 0.05)

NO.	NAME	MATERIAL	FINISH
1	PIN TERM.	BRASS 0.4THK	TIN PLATED
2	SLEEVE TERM.	P.B.S 0.25THK	TIN PLATED
3	BREAK TERM.	BRASS 0.4THK	TIN PLATED
4	HOUSING	P.B.T	BLACK
5	CENTER PIN	BRASS $\phi 0.2$	NICKEL PLATED
6	SHIELD SPERING	BRASS 0.2THK	NICKEL PLATED

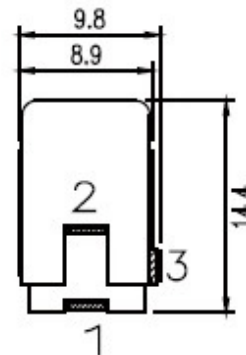

1
TERMINAL NUMBERS

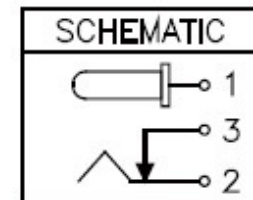

TOPTEK
HARDWARE ELECTRONIC COMPONENTS



www.toptek-co.com