

▶ TERMINAL BLOCK

PCB Terminal block (carrello)



TOPTTEK®

HARDWARE ELECTRONIC COMPONENTS



www.toptek-co.com

SPECIFICATION MODEL KF128 P.5.08 :

1	Screw Material	M3 steel, Zinc plated, “-” slot type
2	Housing Material	PA66, UL94V-0
3	Clamp Material	Brass, Ni plated
4	Pin Header Material	Brass, Tin plated
5	Rated voltage	UL: 300V IEC: 250V
6	Rated Current	UL: 10A IEC: 18A
7	Insulation Resistance	500MΩ / DC500V
8	Withstanding Voltage	AC2000V / 1min
9	Wire Range	26-12AWG 2.5mm ²
10	Operating Temperature	-40°C.....+105°C
11	Soldering Temperature	250°C ± 5 / 5sec
12	Torque	0.5N.m (4.43Lb.in)
13	Strip Length	6-7mm



▶ ORDER INFORMATION

K F 1 2 8 - 5.08 X X P

Pitch:mm

No.of Poles

2~24P

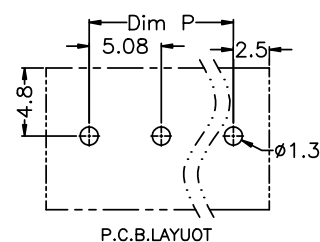
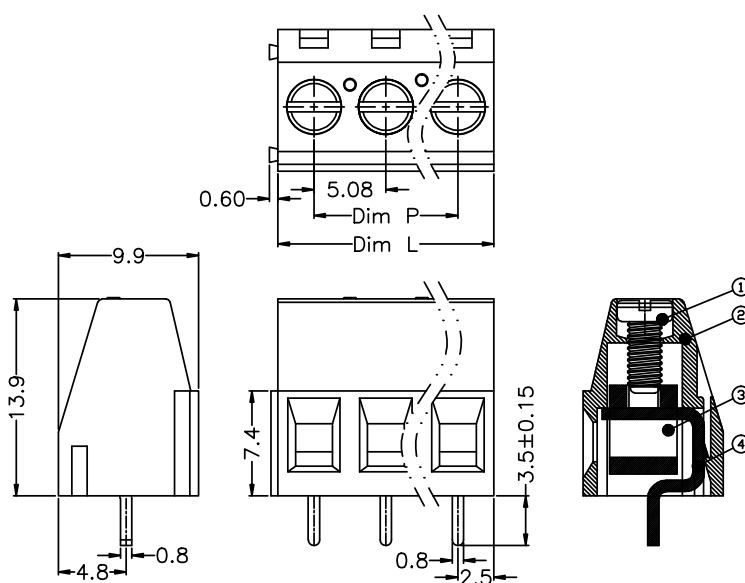

N=Number of Poles
 Dim P=(N-1)×5.08
 Dim L=N×5.08

Poles	Dim	Dim P	Dim L
2-6P		±0.10	±0.15
7-12P		±0.20	±0.20
13-18P		±0.25	±0.30
19-24P		±0.30	±0.40